

Scope of Performance LVS (R)

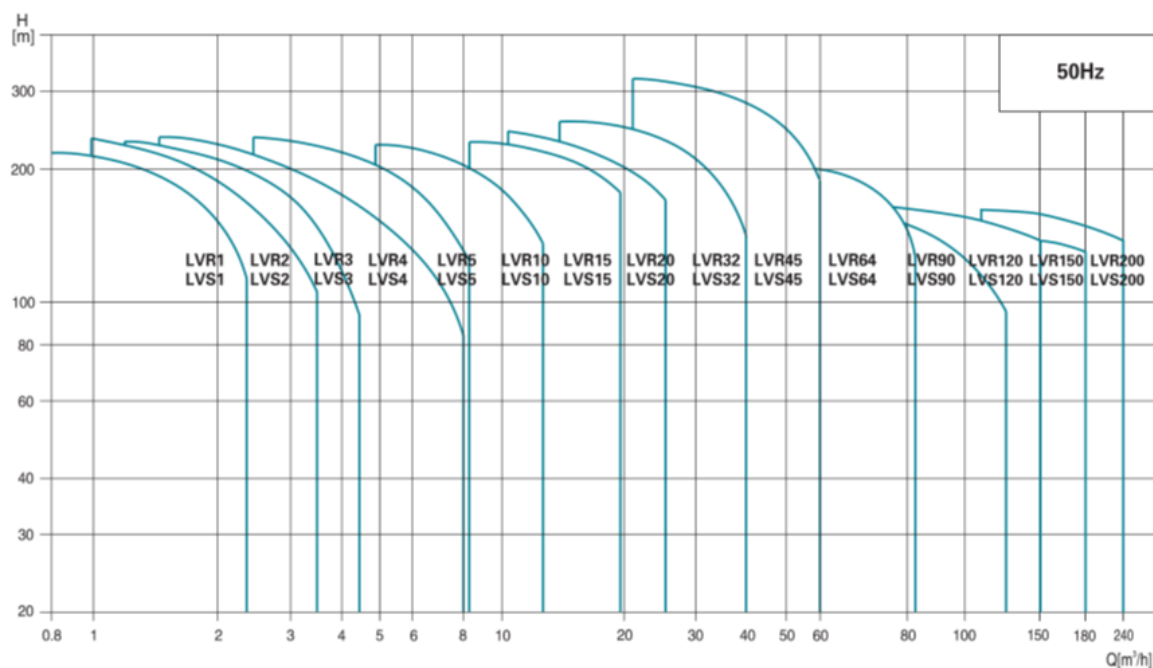

Product Range

MODEL	LVR(S)1	LVR(S)2	LVR(S)3	LVR(S)4	LVR(S)5	LVR(S)10	LVR(S)15	LVR(S)20	LVR(S)32	LVR(S)45	LVR(S)64	LVR(S)90	LVR(S)120	LVR(S)150	LVR(S)200
DESCRIPTION															
Rated flow [m³/h]	1	2	3	4	5	10	15	20	32	45	64	90	120	150	200
Flow range [m³/h]	0.7-2.4	1.0-3.5	1.2-4.5	1.5-8	2.5-8.5	5-13	8-23	10.5-29	15-40	22-58	30-85	45-120	60-150	80-180	100-240
Max. pressure [bar]	22	23	24	21	24	22	23	25	28	33	22	20	16	16	16
Motor power [kW]	0.37-2.2	0.37-3	0.37-3	0.37-4	0.37-4	1.1-7.5	1.1-15	1.1-18.5	1.5-30	3-45	4-45	5.5-45	11-75	11-75	18.5-110
Temperature Range [°C]	-20°C--+120°C (Note: Both the Max. permissible pressure and liquid temperature range refer to the pump capacity.)														
Max. pump efficiency [%]	45	46	55	59	60	65	70	72	78	79	80	81	74	73	79
Pipe connection-LVR															
Oval flange	G1	G1	G1	G1 1/4	G1 1/4	-	-	-	-	-	-	-	-	-	-
DIN flange	DN25	DN25	DN25	DN32	DN32	DN40	DN50	DN50	DN65	DN80	DN100	DN100	DN125	DN125	DN150
Pipe connection-LVS															
Oval flange	-	-	-	-	-	-	-	-	-	-	-	-	-	-	-
DIN flange	DN32	DN32	DN32	DN32	DN32	DN40	DN50	DN50	DN65	DN80	DN100	DN100	DN125	DN125	DN150
Clamp connector	φ42	φ42	φ42	φ42	φ42	-	-	-	-	-	-	-	-	-	-
Threaded connector	R ₂ 1 1/4	R ₂ 1 1/4	R ₂ 1 1/4	R ₂ 1 1/4	R ₂ 1 1/4	-	-	-	-	-	-	-	-	-	-

Ambient Temperature

An ambient temperature of over 40 ° C or an installation at an altitude above 1000 meters above sea level requires an oversized motor. Due to low air density and poor cooling, the output power P_2 decreases, as shown in the table below:

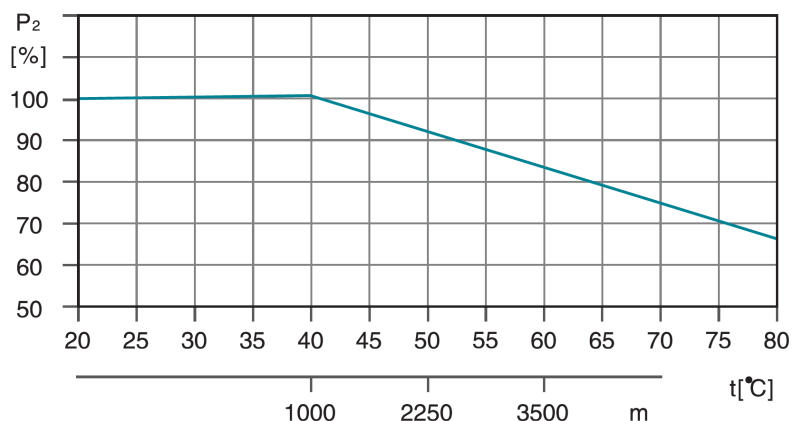

For example, when the pump is installed at an altitude of 3500 meters, P_2 will decrease by 88%. And when the ambient temperature is 70 ° C, P_2 will decrease by 78%.

Maximum Operation pressure (bar)

The table below shows the maximum discharge pressures of the various LVS (R) pumps. The suction pressure of the pump + the set pressure must always be lower than the maximum operating pressure of the pump. If the maximum working pressure is exceeded, it can damage the motor bearings and reduce the service life of the mechanical seal.

Model	LVR Max. Operation pressure [bar]		LVS Max. Operation pressure [bar]
	Oval Flange	DIN Flange	
LVR (S) 1	16	25	25
LVR (S) 2	16	25	25
LVR (S) 3	16	25	25
LVR (S) 4	16	25	25
LVR (S) 5	16	25	25
LVR (S) 10		25	25
LVR (S) 15		25	25
LVR (S) 20		25	25
LVR (S) 32-1-1 - 32-7	16		16
LVR (S) 32-8-2 - 32-14	30		30
LVR (S) 45-1-1 - 45-5	16		16
LVR (S) 45-6-2 - 45-11	30		30
LVR (S) 45-12-2 - 45-13-2	33		33
LVR (S) 64-1-1 - 64-5	16		16
LVR (S) 64-6-2 - 64-8-1	30		30
LVR (S) 90-1-1 - 90-4	16		16
LVR (S) 90-5-2 - 90-6	30		30
LVR (S) 120-1 - 120-7	20		20
LVR (S) 150-1-1 - 150-6	20		20
LVR (S) 200-1-D - 200-4	20		20

NPSH

Minimum Inlet Pressure–Npsh

Calculation of the inlet pressure “H” is recommended in these situations:

- The liquid temperature is high.
- The flow is significantly higher than the rated flow.
- Water is drawn from depths.
- Water is drawn through long pipes.
- Inlet conditions are poor.

To avoid cavitation, make sure that there is a minimum pressure on the suction side of the pump. The maximum suction lift “H” in meters head can be calculated as follows:

$$H = P_b \times 10.2 - NPSH - H_f - H_v - H_s$$

P_b = Barometric pressure in bar. (Barometric pressure can be set to 1 bar). In closed systems, P_b indicates the system pressure in bar.

NPSH = Net Positive Suction Head in meters head. (To be read from the NPSH curve at the highest flow the pump will be delivering.)

H_f = Friction loss in suction pipe in meters head. (At the highest flow the pump will be delivering.)

H_v = Vapor pressure in meters head. (To be read from the vapor pressure scale. “ H_v ” depends on the liquid temperature “ t_m ”)

H_s = Safety margin=minimum 0.5 meters head.

If the “H” calculated is positive, the pump can operate at a suction lift of maximum “H” meters head.

If the “H” calculated is negative, an inlet pressure of minimum “H” meters head is required.



t_m [°C]	H_v [m]
190	126
180	100
170	79
160	62
150	45
140	40
140	35
130	30
130	25
120	20
110	15
100	12
100	10
90	8.0
90	6.0
80	5.0
80	4.0
70	3.0
60	2.0
50	1.5
50	1.0
40	0.8
40	0.6
30	0.4
30	0.3
20	0.2
10	0.1
0	0

Note: To avoid cavitation, never select a pump with a duty point too far to the right on the NPSH curve. Always check the NPSH value of the pump at the highest possible flow.

LVR4 Vertical multicellular pump, water box and pump base in cast iron



LVR

Application

- Transfer of liquids with low viscosity, non-flammable and non-explosive, not containing solid particles or fibers. These liquids must not chemically attack the materials of the pump.
- Water supply for tall buildings, pumping stations, overpressure
- Washing stations, heating water circulation, air conditioning water circulation, water treatment systems
- Distillation systems, municipal swimming pools
- Irrigation: sprinkling, drip
- Industry
- Fire fighting systems

Pompe

- Liquid temperature: from -20°C to +120°C
- Nominal flow: 4 m³/h
- maximum pressure: 21 bars
- pH between 4 and 10

Moteur

- IE3 motor
- Protection class: IP55
- Maximum ambient temperature: +40°

Identification codes

LVR m 4 -10 -B /F(A, K, G)

- DIN flange (oval, clamp fitting, threaded fitting)
- inox 316 (by default, inox 304)
- number of turbines
- Nominal flow (m³/h)
- Single-phase motor
- vertical multicellular pump in cast iron

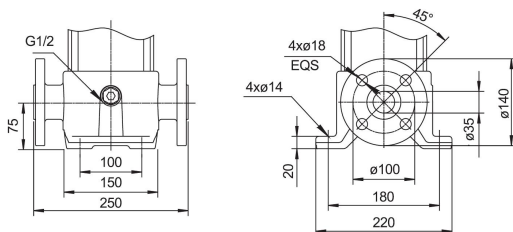

DIN flange (/F)

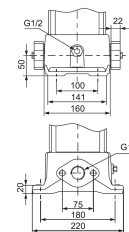

Oval flange (/A)

Options

Technical data

MODEL	kW	Q (m ³ /h)	1.5	2	3	4	5	6	7	8
		Q (l/min)	25	33	50	67	83	100	117	133
LVRm4-2	0.37		19	18	17	14.5	13	10.5	8	6
LVR4-2	0.37		19	18	17	14.5	13	10.5	8	6
LVRm4-3	0.55		28	27	26	23.5	20	18	14	10
LVR4-3	0.55		28	27	26	23.5	20	18	14	10
LVRm4-4	0.75		38	36	34	31.5	27	24.5	18	13
LVR4-4	0.75		38	36	34	31.5	27	24.5	18	13
LVRm4-5	1.1		47	45	43	40.5	34	31.5	23	17
LVR4-5	1.1		47	45	43	40.5	34	31.5	23	17
LVRm4-6	1.1		56	54	52	47.5	41	36	28	20
LVR4-6	1.1		56	54	52	47.5	41	36	28	20
LVRm4-7	1.5		66	63	61	57	48	44.5	34	24
LVR4-7	1.5		66	63	61	57	48	44.5	34	24
LVRm4-8	1.5		74	72	70	64	55	49.5	38	27
LVR4-8	1.5		74	72	70	64	55	49.5	38	27
LVRm4-9	2.2		86	81	78	72	63	56	44	32
LVR4-9	2.2		86	81	78	72	63	56	44	32
LVRm4-10	2.2		96	90	87	81	71	64	50	34
LVR4-10	2.2		96	90	87	81	71	64	50	34
LVRm4-11	2.2		105	99	95	88	78	69	53	39
LVR4-11	2.2		105	99	95	88	78	69	53	39
LVRm4-12	2.2		114	108	104	96	85	75	57	41
LVR4-12	2.2		114	108	104	96	85	75	57	41
LVRm4-13	3		123	117	113	103	93	83	63	45
LVR4-13	3		123	117	113	103	93	83	63	45
LVRm4-14	3		136	126	122	114	101	90	69	48
LVR4-14	3		136	126	122	114	101	90	69	48
LVRm4-15	3		142	135	131	120	108	96	73	52
LVR4-15	3		142	135	131	120	108	96	73	52
LVRm4-16	3		152	144	140	129	115	102	78	55
LVR4-16	3		152	144	140	129	115	102	78	55
LVR4-17	4		163	153	149	137	122	108	83	62
LVR4-18	4		175	162	158	145	129	115	89	65
LVR4-19	4		183	171	168	155	137	123	95	67
LVR4-20	4		192	180	176	161	144	128	99	72
LVR4-21	4		203	197	184	169	152	134	103	75
LVR4-22	4		211	200	192	177	160	139	108	79

Hydraulic performance

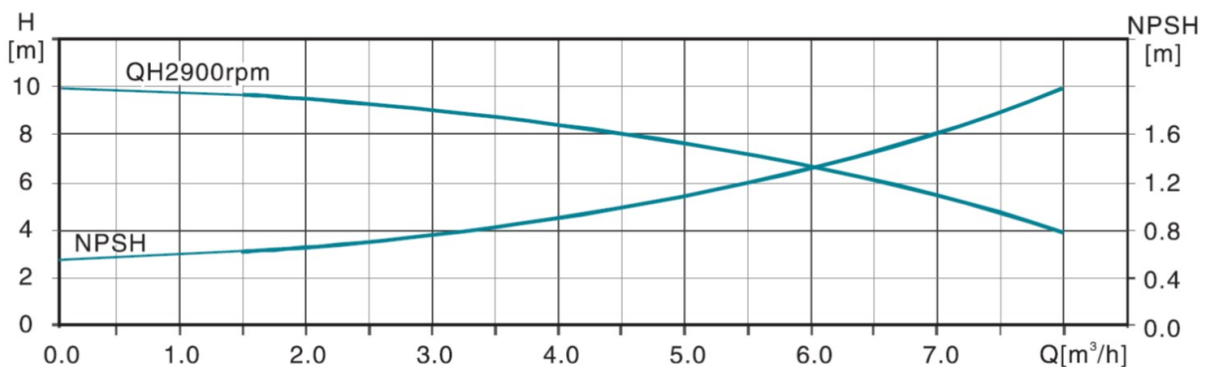
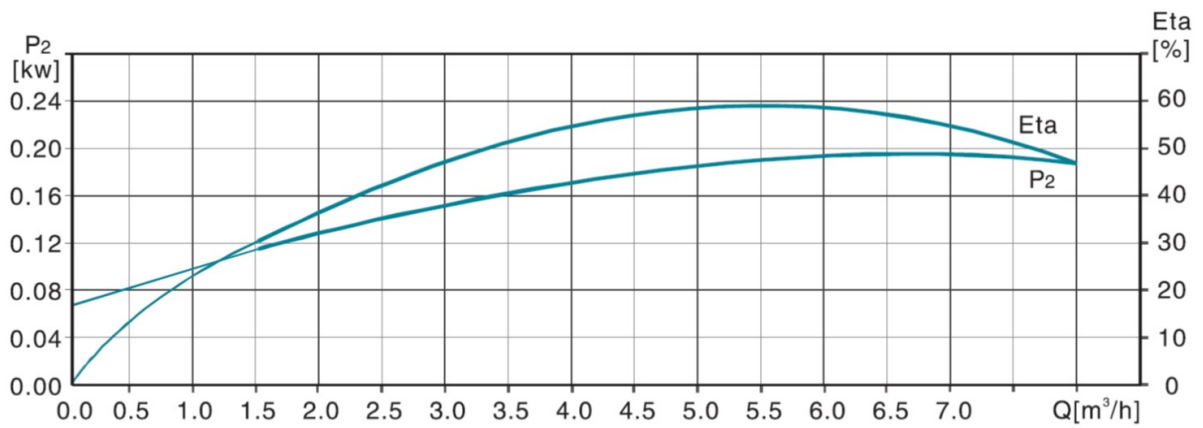
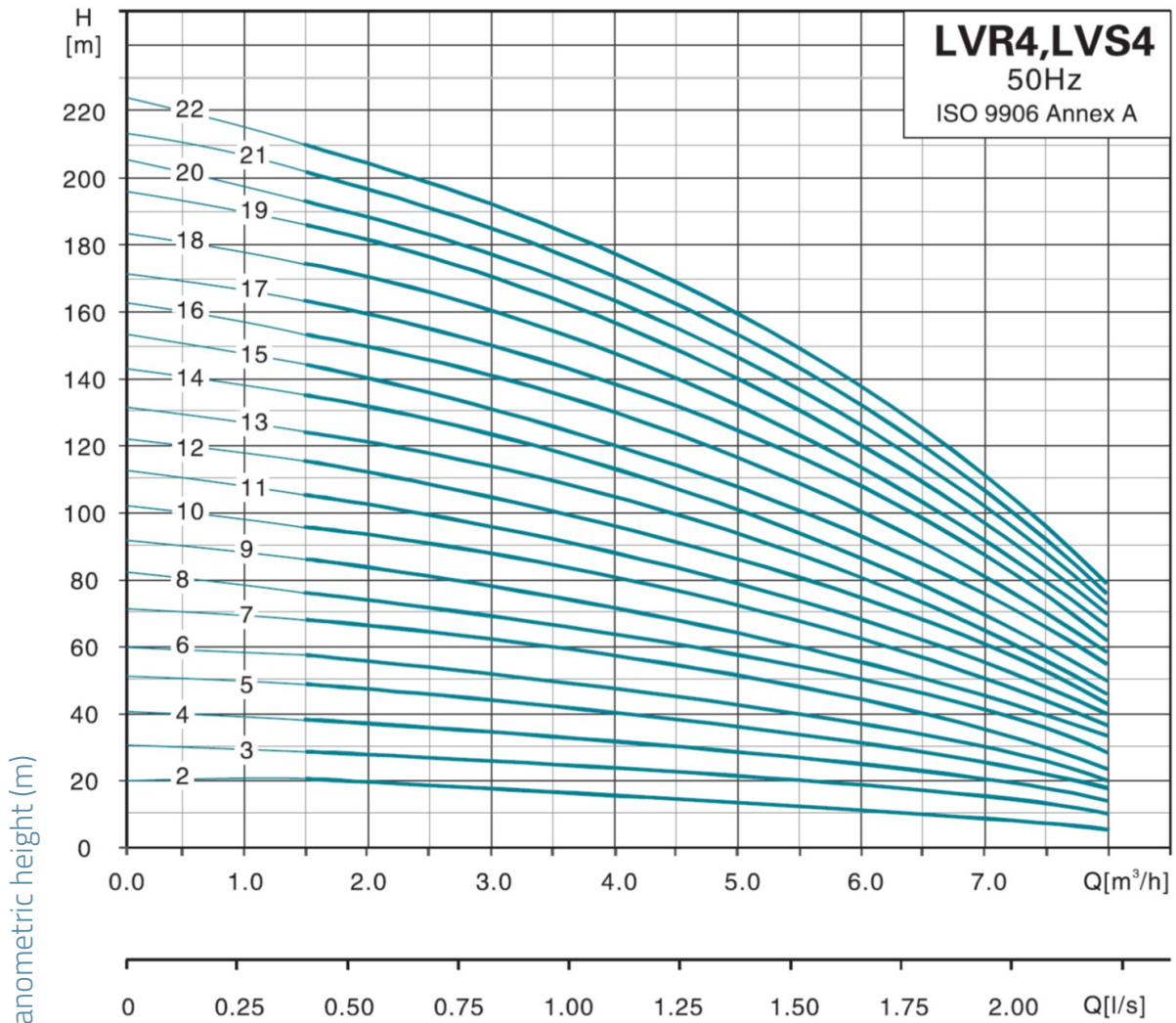

Dimensions

MODEL	B1/bride-ovale	B1+B2/bride-ovale	B1/bride-DIN	B1+B2/bride-DIN	D1	D2	poids
LVRm4-2	256	470	282	496	130	105	22.4
LVR4-2	256	470	282	496	130	105	22.4
LVRm4-3	283	497	309	523	130	105	23
LVR4-3	283	497	309	523	130	105	23
LVRm4-4	214	582	340	608	150	125	25.2
LVR4-4	214	582	340	608	150	125	25.2
LVRm4-5	341	609	367	635	150	125	27.2
LVR4-5	341	609	367	635	150	125	27.2
LVRm4-6	368	636	394	662	150	125	27.4
LVR4-6	368	636	394	662	150	125	27.4
LVRm4-7	411	729	437	755	164	127	34.4
LVR4-7	411	729	437	755	164	127	34.4
LVRm4-8	438	756	646	782	164	127	35.6
LVR4-8	438	756	646	782	164	127	35.6
LVRm4-9	465	783	491	809	164	127	35.9
LVR4-9	465	783	491	809	164	127	35.9
LVRm4-10	492	810	518	836	164	127	36.9
LVR4-10	492	810	518	836	164	127	36.9
LVRm4-11	519	837	545	863	164	127	38.7
LVR4-11	519	837	545	863	164	127	38.7
LVRm4-12	546	864	572	890	164	127	39.8
LVR4-12	546	864	572	890	164	127	39.8
LVRm4-13	577	917	603	943	186	120	47.6
LVR4-13	577	917	603	943	186	120	47.6
LVRm4-14	604	944	630	970	186	120	48.2
LVR4-14	604	944	630	970	186	120	48.2
LVRm4-15	631	971	657	997	186	120	48.8
LVR4-15	631	971	657	997	186	120	48.8
LVRm4-16	658	998	684	1024	186	120	49.3
LVR4-16	658	998	684	1024	186	120	49.3
LVR4-17	685	1025	711	1051	186	120	50.9
LVR4-18	712	1052	738	1078	186	120	53.1
LVR4-19	739	1079	765	1105	186	120	53.4
LVR4-20	766	1106	792	1132	186	120	53.6
LVR4-21	793	1133	819	1159	186	120	53.9
LVR4-22	820	1160	846	1186	186	120	54.2

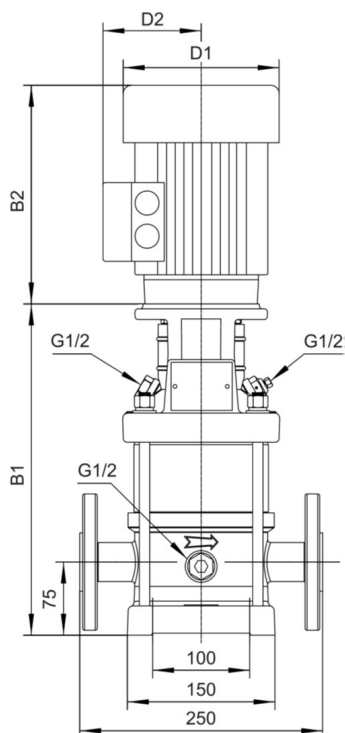

Exploded view

No.	Type	Materials
1	Lower water box	cast iron HT200
2	Drain plug	AISI 304 stainless steel
3	Diffuser	AISI 304 stainless steel
4	Diffuser with bearing	AISI 304 stainless steel
5	Intermediate diffuser	AISI 304 stainless steel
6	Impeller	AISI 304 stainless steel
7	Final scroll	AISI 304 stainless steel
8	Lantern	cast iron HT200
9	Filling plug	AISI 304 stainless steel
10	Coupling	
11	Engine	
12	Coupling protection housing	AISI 304 stainless steel
13	Cartridge mechanical seal	
14	Drain plug	AISI 304 stainless steel
15	Pump shaft	AISI 304 stainless steel
16	Jacket	AISI 304 stainless steel
17	Flange	cast iron HT200

